

Levenhuk MED 10 Microscopes

- ⓔN User Manual
- ⓔG Ръководство за потребителя
- ⓔZ Návod k použití
- ⓔE Bedienungsanleitung
- ⓔS Guía del usuario
- ⓔHU Használati útmutató
- ⓔIT Guida all'utilizzo
- ⓔPL Instrukcja obsługi
- ⓔPT Manual do usuário
- ⓔRU Инструкция по эксплуатации



*Наслади се отблизо
Radost zaostřit
Zoom ran und hab Fun!
Amplie y disfrute
Kellemes nagyítást!
Ingrandisci il divertimento
Radość przybliżania
Dê um zoom na sua emoção
Приближает с удовольствием*

levenhuk
Zoom&Joy

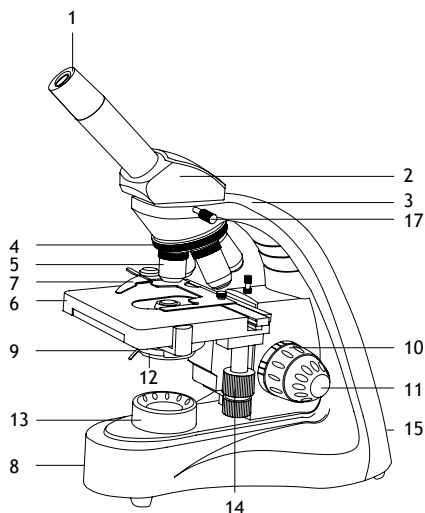

1a. Levenhuk MED 10M

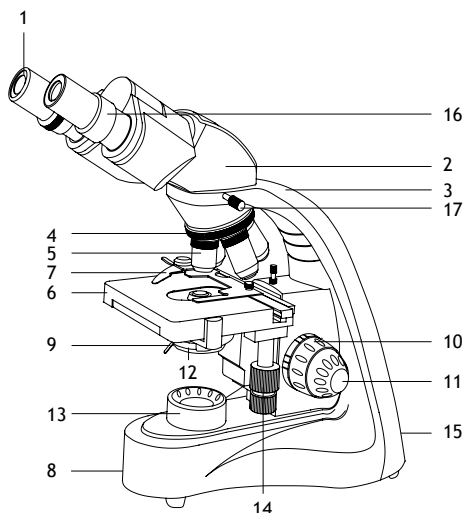

1b. Levenhuk MED 10B

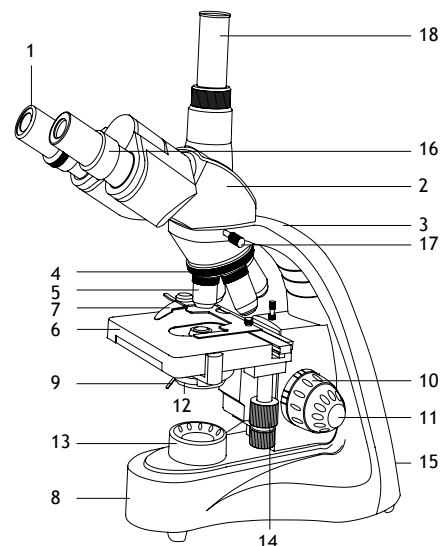

1c. Levenhuk MED 10T,
MED D10T, MED D10T LCD

EN

1. Eyepiece
2. Monocular/binocular/trinocular eyepiece head
3. Arm
4. Revolving nosepiece
5. Objective
6. Stage
7. Mechanical scale
8. Brightness adjustment knob (not shown)
9. Aperture diaphragm adjustment rod
10. Coarse focusing knob
11. Fine focusing knob
12. Condenser with filter holder
13. Illumination
14. Stage moving knob (right/left and back/forth)
15. Illumination on/off button (not shown)
16. Diopter adjustment ring (binocular and trinocular models only)
17. Monocular/binocular/trinocular head locking screw
18. Third eyepiece tube (trinocular models only)

BG

1. Окуляр
2. Монокулярна/бинокулярна/тринокулярна глава
3. Рамо
4. Револверна глава
5. Обектив
6. Предметна маса
7. Механична скала
8. Бутон за регулиране на яркостта (не е показан)
9. Лостче за регулиране на апертурата на диафрагмата
10. Бутон за грубо фокусиране
11. Бутон за фино фокусиране
12. Кондензатор с държач за филтри
13. Осветление
14. Бутон за преместване на предметната маса (надясно/наляво и назад/напред)
15. Бутон за включване/изключване на осветлението (не е показан)
16. Пръстен за регулиране на диоптъра
17. Заклучващ винт на монокулярната/бинокулярната/тринокулярната глава
18. Трета тръба на окуляра (само за тринокулярни модели)

CZ

1. Okulár
2. Monokulární/binokulární/trinokulární hlava okuláru
3. Rameno
4. Revolverový nosič objektivů
5. Objektiv
6. Pracovní stolec
7. Mechanická stupnice
8. Knoflík pro nastavení jasu (není zobrazen)
9. Páčka pro nastavení aperturní clony
10. Makrošroub pro hrubé zaostření
11. Mikrošroub pro jemné zaostření
12. Kondenzor s držákem filtru
13. Osvětlení
14. Ovládací knoflík posuvu pracovního stolku (vpravo/vlevo a dozadu/dopředu)
15. Tlačítko zapnutí/vypnutí osvětlení (není zobrazeno)
16. Kroužek dioptrické korekce
17. Pojistný šroub monokulární/binokulární/trinokulární hlavy
18. Třetí tubus okuláru (pouze trinokulární modely)

DE

1. Okular
2. Monokular-/Binokular-/Trinokular-Okularkopf
3. Arm
4. Revolver
5. Objektiv
6. Objektisch
7. Physische Skala
8. Helligkeitsregler (nicht abgebildet)
9. Irisblende-Einstellstab
10. Grobtrieb
11. Feintrieb
12. Kondensator mit Filterhalter
13. Beleuchtung
14. Tischverstellungsknopf (links/rechts/ vorwärts/rückwärts)
15. Beleuchtung-Ein-/Ausschalter (nicht abgebildet)
16. Dioptrienring
17. Monokular-/Binokular-/Trinokularkopf-Fixierschraube
18. Dritter Okulartubus (nur Trinokularmodelle)

ES

1. Ocular
2. Cabezal monocular / binocular / trinocular
3. Brazo
4. Revólver giratorio
5. Objetivo
6. Platina
7. Micrómetro mecánico
8. Mando de ajuste del brillo (no se muestra)
9. Varilla de ajuste del diafragma de apertura
10. Mando de enfoque aproximado
11. Mando de enfoque preciso
12. Condensador con soporte de filtro
13. Iluminación
14. Mando de movimiento de la platina (derecha/izquierda y atrás/adelante)
15. Botón de encendido/apagado de la iluminación (no se muestra)
16. Anillo de ajuste de las dioptrías
17. Tornillo de bloqueo del cabezal monocular/binocular/trinocular
18. Tercer tubo ocular (solo modelos trinoculares)

IT

1. Oculare
2. Testata monoculare/binoculare/trinoculare
3. Stativo
4. Revolver portaobiettivi
5. Obiettivo
6. Tavolino
7. Traslatore meccanico
8. Manopola di regolazione della luminosità (non visibile)
9. Leva di regolazione dell'apertura del diaframma
10. Manopola di messa a fuoco grossolana
11. Manopola di messa a fuoco fine
12. Condensatore con portafiltro
13. Illuminazione
14. Manopola per il movimento del tavolino (destra/sinistra e avanti/indietro)
15. Interruttore per l'illuminazione (non visibile)
16. Ghiera di regolazione diottrica (solo modelli binoculari e trinoculari)
17. Vite di fissaggio della testata monoculare/binoculare/trinoculare
18. Terzo tubo ottico (solo modelli trinoculari)

PT

1. Ocular
2. Cabeça da ocular monocular/binocular/trinocular
3. Braço
4. Revólver giratório
5. Objetiva
6. Platina
7. Balança mecânica
8. Botão de ajuste do brilho (não apresentado)
9. Haste de ajuste do diafragma de abertura
10. Botão de focagem grosseira
11. Botão de focagem fina
12. Condensador com suporte do filtro
13. Iluminação
14. Botão de deslocação da lâmina (para a direita/para a esquerda e para a frente/para trás)
15. Botão de ligar/desligar a iluminação (não apresentado)
16. Anel de ajuste de dioptria
17. Parafuso de bloqueio da cabeça monocular/binocular/trinocular
18. Terceiro tubo ocular (apenas modelos Trinocular)

HU

1. Szemlencse
2. Egy-/kettő-/háromszemlencsés szemlencse fejrész
3. Kar
4. Revolverfej
5. Objektív
6. Tárgyasztal
7. Mechanikus skála
8. Fényerősség állítógomb (nem látható)
9. Rekesznyílás állítórúd
10. Durva-fókuszállító gomb
11. Finom-fókuszállító gomb
12. Kondenzor szűrőtartóval
13. Megvilágítás
14. Tárgyasztal mozgó gomb (jobb/bal és előre/hátra)
15. Világítás be-/kikapcsoló gomb (nem látható)
16. Dioptria-állító gyűrű (csak kettő-/háromszemes modelleknél)
17. Egy-/kettő-/háromszemes fejrész rögzítőcsavar
18. Harmadik szemlencsecső (csak háromszemlencsés modelleknél)

PL

1. Okular
2. Głowica monokularowa/dwuokularowa/trójokularowa
3. Ramię
4. Miska rewolwerowa
5. Obiektyw
6. Stolik
7. Skala mechaniczna
8. Pokrętło regulacji jasności (niepokazane)
9. Pręt regulacji przysłony aperturowej
10. Pokrętło zgrubnej regulacji ostrości
11. Pokrętło precyzyjnej regulacji ostrości
12. Kondensator z uchwytem filtra
13. Oświetlenie
14. Pokrętło przesuwania stolika (w prawo/w lewo i do tyłu/ do przodu)
15. Przycisk wł./wyt. oświetlenia (niepokazany)
16. Pierścień regulacji dioptrii
17. Śruba blokująca głowicy monokularowej/dwuokularowej/trójokularowej
18. Tuba trzeciego okularu (tylko modele trójokularowe)

RU

1. Окуляр
2. Монокулярная/бинокулярная/тринокулярная насадка
3. Опорная стойка
4. Револьверное устройство
5. Объектив
6. Предметный столик
7. Препаратоводитель
8. Регулятор яркости подсветки (не показан)
9. Регулятор апертурной диафрагмы
10. Ручка грубой фокусировки
11. Ручка тонкой фокусировки
12. Конденсор с держателем фильтра
13. Блок подсветки
14. Перемещение столика по горизонтали (вправо/влево и вперед/назад)
15. Кнопка вкл/выкл подсветки (не показана)
16. Кольцо диоптрийной настройки
17. Фиксатор монокулярной/бинокулярной/тринокулярной насадки
18. Третья окулярная трубка (только тринокулярные модели)

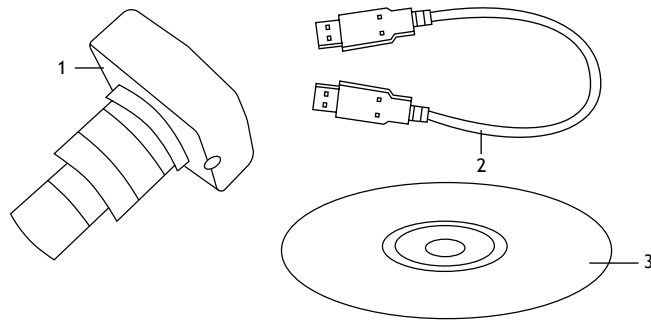

2a. Levenhuk MED D10T

EN

1. Digital camera
2. USB cable
3. Installation CD

BG

1. Цифрова камера
2. USB кабел
3. Инсталационен компактдиск

CZ

1. Digitální fotoaparát
2. Kabel USB
3. Instalační CD

DE

1. Digitalkamera
2. USB-Kabel
3. Installations-CD

ES

1. Cámara digital
2. Cable USB
3. CD de instalación

HU

1. Digitális kamera
2. USB-kábel
3. Telepítő CD

IT

1. Fotocamera digitale
2. Cavo USB
3. CD di installazione

PL

1. Aparat cyfrowy
2. Przewód USB
3. Płyta instalacyjna

PT

1. Câmara digital
2. USB cable
3. CD de instalação

RU

1. Цифровая камера
2. USB-кабель
3. Компакт-диск с программным обеспечением

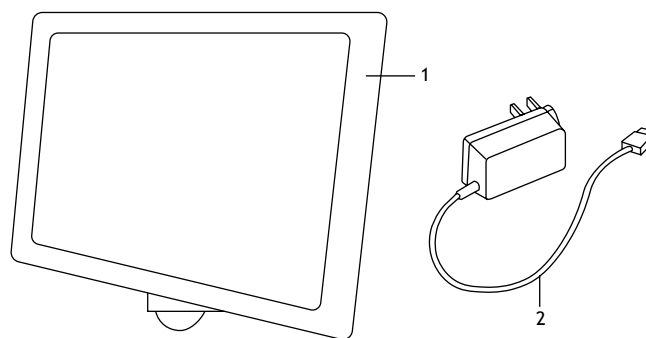

2b. Levenhuk MED D10T LCD

EN

1. Digital camera with LCD screen
2. AC adapter

BG

1. Цифрова камера с течнокристален екран
2. Променливотоков адаптер

CZ

1. Digitální fotoaparát s LCD obrazovkou
2. Síťový adaptér

DE

1. Digitalkamera mit LCD-Bildschirm
2. Netzteil

ES

1. Cámara digital con pantalla LCD
2. Adaptador de CA

HU

1. Digitális kamera LCD-kijelzővel
2. Hálózati adapter

IT

1. Fotocamera digitale con schermo LCD
2. Adattatore AC

PL

1. Aparat cyfrowy z wyświetlaczem LCD
2. Zasilacz sieciowy

PT

1. Câmara digital com ecrã LCD
2. Adaptador de CA

RU

1. Цифровая камера с ЖК-экраном
2. Сетевой адаптер

General Information

Read the user manual carefully before you start working with a microscope. Levenhuk MED Series biological microscopes are safe for health, life and property of the consumer and the environment when properly used, and meets the requirements of international standards. These microscopes are designed for observing transparent objects in the transmitted light using the bright field method. They perform well in clinical research and tests; teaching demonstrations; bacterioscopy and cytology in medical and health establishments, laboratories, universities; and may be used for scientific research in agriculture and microbiology.

Microscope assembly

- Unpack the microscope carefully and place it on a flat surface.
- Remove the plastic bags and dustproof cover of the eyepiece head.
- Install the monocular, binocular or trinocular head and tighten the locking screw.
- Inspect all the items included in the kit and define their purpose.
- Connect the power cord to the microscope and plug it in.

Use

Please refer to the fig. 1a (monocular model), fig. 1b (binocular model) and fig. 1c (trinocular model).

- Turn on the power and the illumination will turn on. Set the brightness at approximately 70%. Place the specimen on the stage. Make sure the clips hold the specimen firmly in place.
- Iris diaphragm should be adjusted in accordance with numerical aperture of a lens. The best practice is to make the iris diaphragm slightly smaller than the aperture of the selected lens. Open or close the iris diaphragm using the adjustment screws. If the adjustment screw is turned to the right, the iris diaphragm is fully open. **Note:** the diaphragm is not intended for adjusting the brightness of the illumination. To adjust the brightness, use the brightness adjustment knob.
- Slide the filter holder, place the filter in it and then return the holder to its initial position.
- To change the objective magnification, turn the revolving nosepiece until it clicks.
- Make sure that the lens does not touch the sample when adjusting the focus: rotate the coarse focus knob until the specimen is about 3.175mm (1/8") away from the lens.
- Looking into the eyepiece, slowly turn the coarse focusing knob until you can see the image of the observed specimen. Turn the fine focusing knob to make the image clear. The fine focusing mechanism allows you to focus on the observed specimen while using high magnifications.
- When you use an oil immersion objective, the space between the specimen and the lens should be filled with immersion oil. Raise the condenser to the upper position and put a drop of oil on the lens and on the cover glass of the specimen. Move the revolving nosepiece back and forth to get rid of air bubbles in the oil. Then, fix the objective lens in its working position. Make sure that oil fills the entire space between the objective lens and the specimen. After use, wipe the lens dry.
- To place the specimen in the field of view, move the stage horizontally back and forth or left and right using the stage moving knob.
- Look through the right eyepiece with your right eye and adjust the image sharpness with the coarse and fine focusing knobs. Binocular and trinocular models: Then, look through the left eyepiece with your left eye and rotate the diopter adjustment ring to equalize the difference between your left and right eyes vision. Remember the setting for future use. Adjust the distance between the eyepiece tubes of the binocular head so that the image merges into a single circle.
- Trinocular models: you can install the digital camera to the third eyepiece tube.

Fuse replacement

Unplug the microscope from a power source. Open the fuse holder located on the back of the microscope body with a flat head screwdriver. Remove the old fuse and install a new one. Only use the appropriate types of fuses. Close the fuse holder.

Digital camera

Levenhuk MED D10T comes with a digital camera (fig. 2a), Levenhuk MED D10T LCD comes with a digital camera with an LCD screen (fig. 2b). A digital camera is installed to the third eyepiece tube and enables observing specimens on the screen in exquisite detail and true color, taking photos and videos, and saving the images for future reference.

Specifications

Product ID	73983	73984	73985	73986	73987
Model	MED 10M	MED 10B	MED 10T	MED D10T	MED D10T LCD
Type	biological/optical			biological/optical, digital	
Research method	bright field			bright field	
Magnification	40–1000x			40–1000x	
Interpupillary distance	–	48–75mm		48–75mm	
Eyepiece head	monocular, 360° rotatable, inclined at 45°	binocular, 360° rotatable, inclined at 30°	trinocular, 360° rotatable, inclined at 30°	trinocular, 360° rotatable, inclined at 30°	
Optics material	optical glass with an anti-fungal coating			optical glass with an anti-fungal coating	
Eyepiece tube diameter	21mm (internal), 26mm (external, with thread)	23.2mm		23.2mm	
Third vertical eyepiece tube	–		23.2mm	23.2mm	
Eyepieces	WF10x/18mm (1pc)	WF10x/18mm (2pcs)		WF10x/18mm (2pcs)	
Eyepiece diopter adjustment	–	±5D		±5D	
Objectives	achromatic: 4x, 10x, 40xs, 100xs (oil)			achromatic: 4x, 10x, 40xs, 100xs (oil)	
Revolving nosepiece	4 objectives			4 objectives	
Stage moving range	70/50mm			70/50mm	
Stage	double layer mechanical, 125x130mm, with a mechanical scale			double layer mechanical, 125x130mm, with a mechanical scale	
Focus system	coaxial, coarse (30mm) and fine (0.002mm)			coaxial, coarse (30mm) and fine (0.002mm)	
Condenser	Abbe N.A. 1.25 iris diaphragm and filter holder			Abbe N.A. 1.25 iris diaphragm and filter holder	
Body	metal			metal	
Illumination	lower (5W LED) with brightness adjustment			lower (5W LED) with brightness adjustment	
Filters	blue, green, yellow			blue, green, yellow	
Vial of immersion oil	+			+	
Fuse	2pcs			2pcs	
Power supply	100–240V, via AC adapter			100–240V, via AC adapter	
Digital camera	–			5.1Mpx	5Mpx with LCD screen
Camera power supply	–			DC 5V, via USB 2.0 cable	DC 12V/2A, via AC adapter
Optional accessories (sold separately)	<i>semi plan objectives: 4x, 10x, 20xs, 40xs, 60xs, 100xs (oil)</i>			<i>semi plan objectives: 4x, 10x, 20xs, 40xs, 60xs, 100xs (oil)</i>	
	<i>plan objectives: 4x, 10x, 20xs, 40xs, 60xs, 100xs (oil)</i>			<i>semi plan objectives: 4x, 10x, 20xs, 40xs, 60xs, 100xs (oil)</i>	
	–	<i>eyepieces (D 23.2mm): 5x, 12.5x, 16x, 20x</i>		<i>eyepieces (D 23.2mm): 5x, 12.5x, 16x, 20x</i>	
	<i>dark field condenser</i>			<i>dark field condenser</i>	
	–	<i>digital camera</i>		–	

Levenhuk reserves the right to modify or discontinue any product without prior notice.



Caution! Please remember that mains voltage in most European countries is 220–240V. If you want to use your device in a country with a different mains voltage standard, remember that use of a converter is absolutely necessary. The microscope must be grounded. Make sure that the main voltage matches the voltage indicated on the microscope body.

Care and maintenance

- **Never, under any circumstances, look directly at the Sun, another bright source of light or at a laser through this device, as this may cause PERMANENT RETINAL DAMAGE and may lead to BLINDNESS.**
- Take necessary precautions when using the device with children or others who have not read or who do not fully understand these instructions.
- After unpacking your microscope and before using it for the first time check for integrity and durability of every component and connection.
- Do not try to disassemble the device on your own for any reason. For repairs and cleaning of any kind, please contact your local specialized service center.
- Protect the device from sudden impact and excessive mechanical force. Do not apply excessive pressure when adjusting focus. Do not overtighten the locking screws.
- Do not touch the optical surfaces with your fingers. To clean the device exterior, use only special cleaning wipes and special optics cleaning tools from Levenhuk. Do not use any corrosive or acetone-based fluids to clean the optics.
- Abrasive particles, such as sand, should not be wiped off lenses, but instead blown off or brushed away with a soft brush.
- Do not use the device for lengthy periods of time, or leave it unattended in direct sunlight. Keep the device away from water and high humidity.
- Be careful during your observations, always replace the dust cover after you are finished with observations to protect the device from dust and stains.
- If you are not using your microscope for extended periods of time, store the objective lenses and eyepieces separately from the microscope.
- Store the device in a dry, cool place away from hazardous acids and other chemicals, away from heaters, open fire and other sources of high temperatures.
- When using the microscope, try not to use it near flammable materials or substances (benzene, paper, cardboard, plastic, etc.), as the base may heat up during use, and might become a fire hazard.
- Always unplug the microscope from a power source before opening the base or changing the illumination lamp. Regardless of the lamp type (halogen or incandescent), give it some time to cool down before trying to change it, and always change it to a lamp of the same type.
- Always use the power supply with the proper voltage, i.e. indicated in the specifications of your new microscope. Plugging the instrument into a different power outlet may damage the electric circuitry of the microscope, burn out the lamp, or even cause a short circuit.
- **Seek medical advice immediately if a small part or a battery is swallowed.**

Levenhuk International Lifetime Warranty

All Levenhuk telescopes, microscopes, binoculars and other optical products, except for accessories, carry a **lifetime warranty** against defects in materials and workmanship. Lifetime warranty is a guarantee on the lifetime of the product on the market. All Levenhuk accessories are warranted to be free of defects in materials and workmanship for **six months** from date of retail purchase. Levenhuk will repair or replace such product or part thereof which, upon inspection by Levenhuk, is found to be defective in materials or workmanship. As a condition to the obligation of Levenhuk to repair or replace such product, the product must be returned to Levenhuk together with proof of purchase satisfactory to Levenhuk.

This warranty does not cover consumable parts, such as bulbs (electrical, LED, halogen, energy-saving and other types of lamps), batteries (rechargeable and non-rechargeable), electrical consumables etc.

For further details, please visit our web site: www.levenhuk.com/warranty

If warranty problems arise, or if you need assistance in using your product, contact the local Levenhuk branch.